



FULLY REDUNDANT DISPLAY MANAGEMENT SYSTEM

IHSE KVM SYSTEM ENHANCES SECURITY AND EFFICIENCY IN AIRPORT OPERATIONS

THE CUSTOMER

King Abdulaziz International Airport (KAIA) in Jeddah, Saudi Arabia, is the destination airport for millions of pilgrims who visit the shrines of the city of Mecca from there. The airport presently hosts over 60 domestic and international airlines in its passenger and cargo terminals.

The new terminal covers an area of 670,000 square meters, has 46 passenger air bridges and is expected to accommodate more than 80 million passengers annually by 2035.



Fully redundant KVM matrix system inside the ATC tower

THE CHALLENGE

Due to this massive expansion and the expected increase in air traffic, it was necessary to upgrade the air traffic control data management systems to ensure safe and efficient ATC services.

For the controllers, who need to focus on the critical areas of air traffic management, the best possible working conditions were to be created, free from distractions and interference. In addition to the new tower, the expansion plans included a new building for apron control, a pilot training room with improved technology, a simulation room and upgrades to the existing air traffic control tower.

Innovative Contractors for Advanced Dimensions (ICAD), the system integrator managing the engineering and installation of the new ATC tower, was looking for a partner to develop a next-generation display server KVM system (DSKVM). The system had to meet the highest requirements in terms of operability, image quality, access speed, access and failure safety, redundancy and ergonomics.

THE SOLUTION

ICAD looked at several KVM manufacturers to meet the innovative design and integration requirements for the airport's DSKVM systems. IHSE was chosen due to the company's extensive experience and track record of success with similar applications in mission-critical projects.

In total, the project comprises six DSKVM systems within the new facilities, each consisting of a redundant KVM matrix system with interconnected extender units that link all dedicated workstations and computer systems through the matrix. The individual systems are connected to the General Monitoring System (GMS) via TCP/IP and communicate using SNMP commands. All installed DSKVM systems are designed to be fully redundant. In the unlikely event of a matrix failure, the signals are immediately routed via a fully functional, secondary matrix thanks to redundant data paths at the extenders.

To satisfy one of the main requirements — air traffic controller access to multiple displays from a single keyboard and mouse — IHSE selected its award-winning U-Switch console. This allows controllers to operate up to eight computers from their individual workstation with corresponding displays by simply moving the mouse to the desired display.

THE BENEFIT

The IHSE KVM solution freed up the space-limited control room at the visual top of the tower from the space-consuming, noise- and heat-generating computer systems. These were relocated together with the other servers and computers to lower levels of the tower. They still can be operated in real time by the controllers as if they were sitting directly at the workstations, without delay and in the best image quality despite the physical distance. Users benefit from a noise- and heat-reduced, ergonomic, de-cluttered workstation.

Thanks to the centralization of ATC for the towers and other services including MET, DMAN, AMAN, training and simulation, and technical supervision, the KVM system enables maximum efficiency and productivity while providing a more flexible working environment for air traffic controllers, technicians and managers.

“The new DSKVM makes it easy to access any computer connected through the KVM redundant matrix system.”

Mahmoud Fliefel, Head of the ICAD ATC department

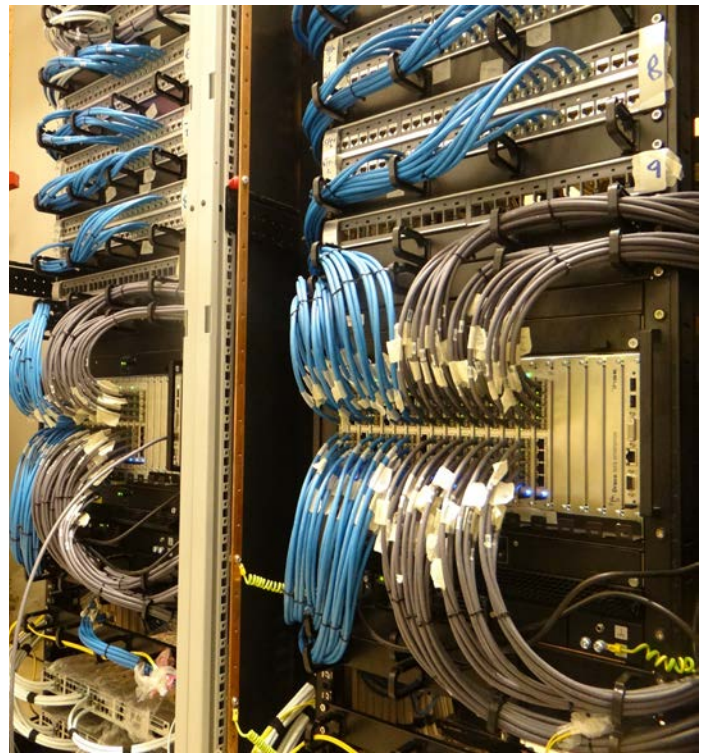

Redundant KVM matrix switch located in the groundfloor of the ATC tower

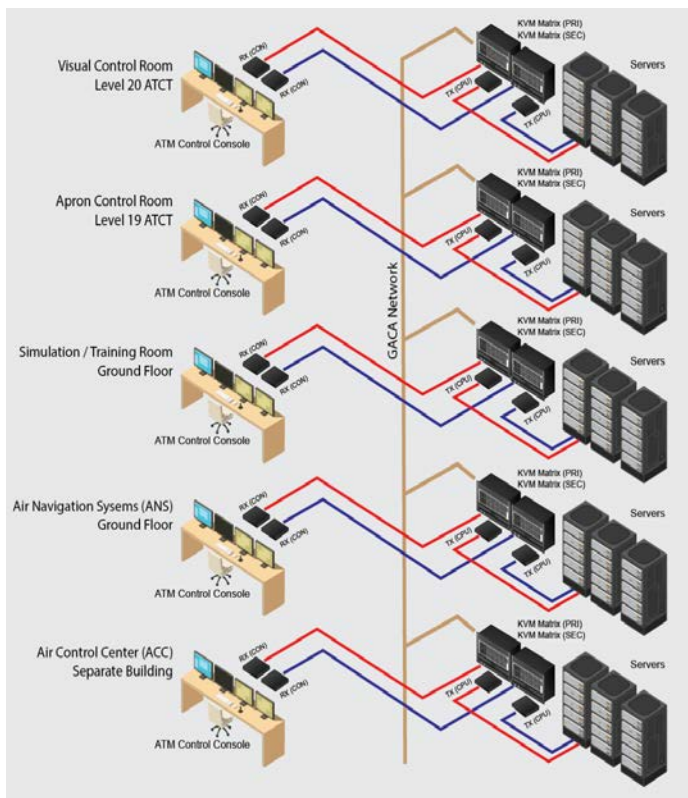

Functional diagram

KVM PRODUCTS IN USE

- Draco tera enterprise matrix switches
- Draco vario extenders
- Draco U-Switch

INSTALLATION

- King Abdulaziz International Airport (KAIA)
- Contractor: ICAD
- Jeddah, Kingdom of Saudi Arabia

CONTACT

IHSE GmbH
Benzstrasse 1
88094 Oberteuringen - Germany

Tel: +49 (7546) 9248-0
E-Mail: info@ihse.com

www.ihse.com